

Laser 4[®]

OPERATION MANUAL

Four Wheel Alignment

TABLE OF CONTENTS

Four Wheel Alignment, Basics	3
Pre-Alignment Checks	4
Four Wheel Alignment Procedures	
Install Wheel Clamps	5
Compensating Wheel Runout	6
Camber Reading	7
Caster Reading	8
Steering Axis Inclination (SAI) Reading	9
Instrumentation Set-up	10
Front Wheel Toe Reading	11
Front Wheel Alignment to Vehicle Centerline	13
Thrust Angle Alignment	14
Total Vehicle Four Wheel Alignment	15
Calibration Procedure	16

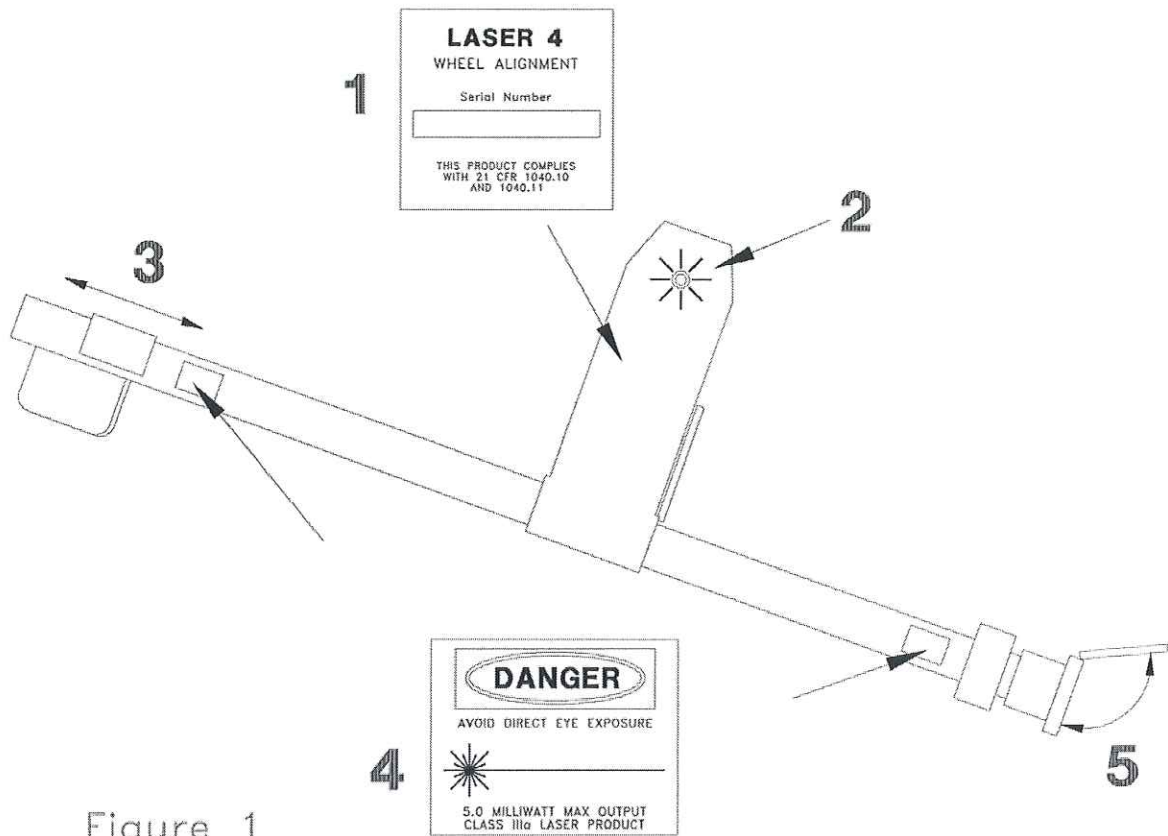

Figure 1

The Laser 4 is a four-wheel alignment system that uses three Class II laser products. These lasers have a maximum output power of 5.0 milliwatts. The laser tubes meet all government safety standards, although common sense dictates that one should not stare directly into the beam. Laser precision is unaffected by light, temperature, and the concentrated light beam is clearly visible anywhere. The following precautions have been taken to insure the safety of the system (See Fig. 1):

- 1) Serial Number label is located on underside of casting on power supply cover. Each serial number is recorded for future identification.
- 2) LED light comes on as soon as power is activated to laser beam.
- 3) Slide cover must be slid toward casting to uncover laser beam (LH Toe Gauge only).
- 4) Caution decals are located on the unit.
- 5) Flip-open protective cap protects laser unit when not in use.

CAUTION: Use of controls or adjustments or performance of procedures other than those specified herein may result in hazardous radiation exposure.

FOUR WHEEL ALIGNMENT

Rear wheels must track and follow the front wheels in a parallel direction with all four wheel adjusted to the common centerline of the vehicle. (See Fig. 2)

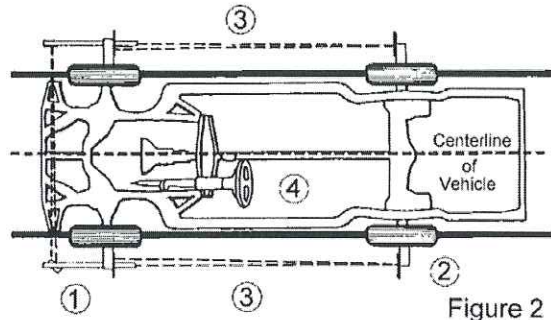

1) Front wheel alignment and front wheel toe on car manufacturer's specifications.

2) Rear wheel alignment and rear wheel toe on car manufacturer's specifications.

3) Front wheels track to rear wheel thrust lines and to centerline of vehicle.

4) Steering wheel centered in straight ahead position.

BASIC STEPS TO DO FOUR WHEEL ALIGNMENTS

Step 1

Adjust front wheel camber and caster to car manufacturer's settings. (See Fig. 3)

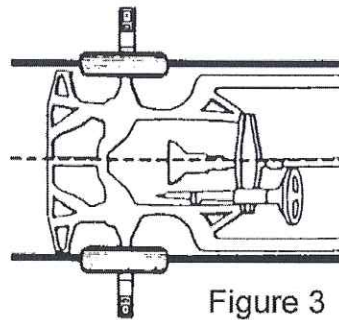

Step 2

Center steering wheel. Adjust front wheel toe to manufacturer's setting. (See Fig. 4)

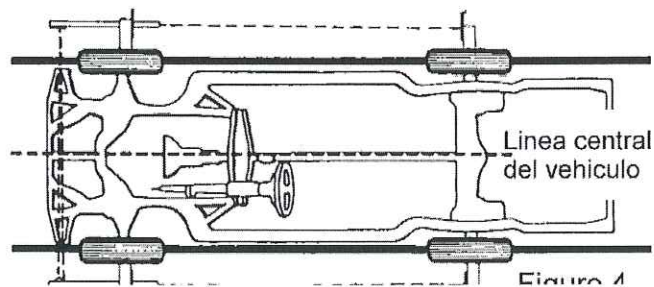

Step 3

Adjust front wheels to rear wheel in relation to rear axle position. (See Fig. 5)

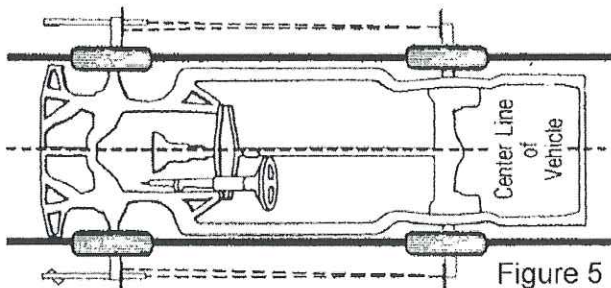

Step 4

Adjust rear wheel camber and toe to car manufacturer's setting.

PRE-ALIGNMENT CHECKS

To maintain a true alignment job; ensure maximum tire mileage and steering safety, it is important to perform certain pre-alignment checks before doing wheel alignment adjustments. They are:

1. Inflate tires to proper inflation pressures.
2. Check car spring height.
3. Check shock absorbers and struts.
4. Inspect steering/suspension parts for wear or looseness. Replace parts which are worn beyond manufacturer's accepted tolerances.
5. Check calibrations of the Laser 4 wheel alignment equipment. See Calibration Procedure section of this manual.

FRONT WHEEL SETBACK

Front wheel setback is a condition in which one front wheel has been driven or pushed back, out of alignment, from the opposite wheel. It is caused by one wheel of the vehicle striking a curb or pothole in the road forcing that wheel back from the other (See Fig. A).

To measure front wheel setback with the Laser 4 wheel alignment system, adjust front wheel toe; center steering wheel, and note the location of the Laser beam on the wheel setback scale (See Fig. B) of the passenger side laser toe gauge. Make sure that the Laser toe gauges are centered on the wheel clamps. The scale reads either right or left wheel setback. The front wheel suspension should be adjusted if the setback is greater than 1/4 inch. Excessive front wheel setback will cause a change in caster.

The Laser 4 alignment system automatically compensates for front wheel setback because of the use of the tapered, precisely ground magnets. When toe is adjusted to zero, the tube of the optical toe gauges become parallel to each other. Front wheel toe reading is unaffected by front wheel setback.

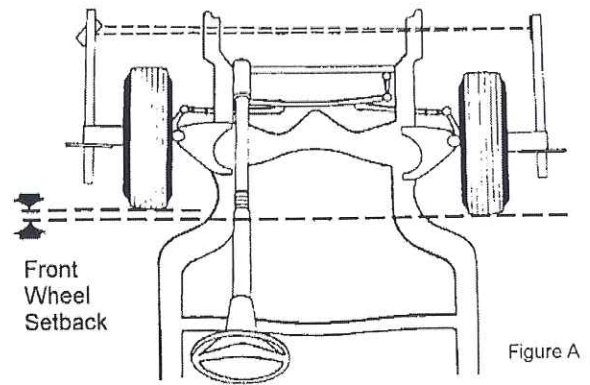

Figure A

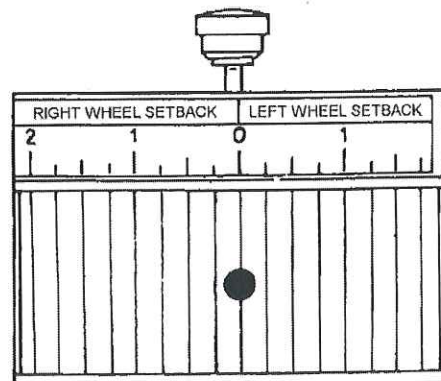

Figure B

INSTALL WHEEL CLAMPS

Install Wheel Clamps on each wheel. (See Fig. 6) Adjust the four bars in each clamp for the best fit to the wheel rim. Two sets of notches on one end or a threaded pin on the other end provide for inside or outside mounting to the wheel rim. Use double-sided foam tape at contact points on decorative or soft metal rims. Make sure that the Wheel Clamps are securely attached.

Select the configuration which gives the most secure fit with the least amount of pressure on the wheel rim.

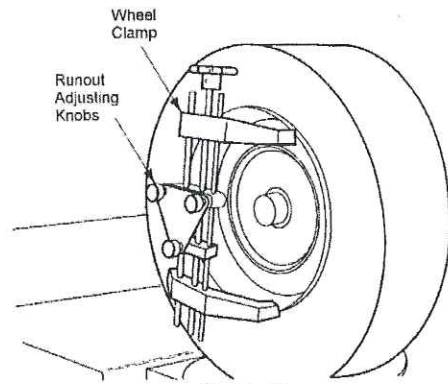

Figure 6

COMPENSATING WHEEL RUNOUT

Wheel Clamps must be adjusted to compensate for wheel runout. This adjustment is made using the three Wheel Runout Adjusting Knobs.

- 1) Raise wheel and tire from turning gauge or rear wheel slip plate. Turn wheel so the large wheel clamping knob is at the top (12 o'clock position).
- 2) Mount the Spirit Level Gauge on the Wheel Clamp. (See Figure 9) Center the magnet on the Wheel Runout Compensating Adapter. Turn the Spirit Level Gauge so it is level.
- 3) Zero the Caster Spirit Level using the adjusting knob on the bottom of the unit.
- 4) Rotate the wheel so the wheel clamp adjusting knob is at the 2 o'clock position. Turn the Spirit Level Gauge so it is once again level. Note the amount of movement of the bubble away from zero.

Repeat at the 4, 6, 8, and 10 o'clock positions. Re-level the Spirit Level Gauge at each position.

- 5) Turn the wheel to the position where the largest movement of the bubble was observed. Turn the Runout Adjusting Knobs to decrease this reading by one-half. Zero the Caster Spirit Level and repeat step 4, checking for the largest movement of the bubble away from zero at each of the six positions.
- 6) The wheel clamp is properly adjusted when the bubble does not move away from zero at all six positions.

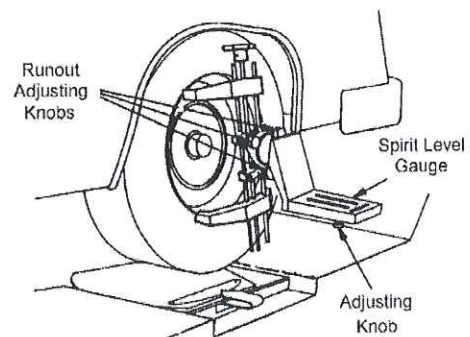

Figure 9

Camber Reading

Proceed with the following steps to read Camber:

- 1) Place front wheels in straight ahead position with steering wheel level. The engine must be started if the vehicle has power steering. Remove locking pins from the turning radius gauges and rear wheel slip plates. Rotate each wheel until the large wheel clamp adjusting knob is at the top.
 - 2) Lower all four wheels until the front wheels rest on the turning radius gauges and the rear wheels rest on the rear wheel slip plates. Be sure turning radius gauges are centered under the front tires.
 - 3) Install brake pedal depressor. The engine must be running if the vehicle has power brakes.
 - 4) Bounce the vehicle at both front and rear to normalize the suspension weight.
 - 5) Mount the Spirit Level Gauge on the left front Wheel Clamp. (See Fig. 13) Be sure the magnet is centered on the mounting disk.
 - 6) Read Camber at the center of the bubble on the Camber Scale. The spirit level for Camber is located on the right side of the gauge. (See Fig. 14)
- Camber is zero when the center of the bubble is on zero of the scale.
- Camber is positive when the bubble is away from zero toward the wheel.
- Camber is negative when the bubble is away from zero, away from the wheel.
- 7) Repeat the above procedure on the right front wheel. If camber adjustments and specifications are available for the rear wheels, repeat the above on each wheel.

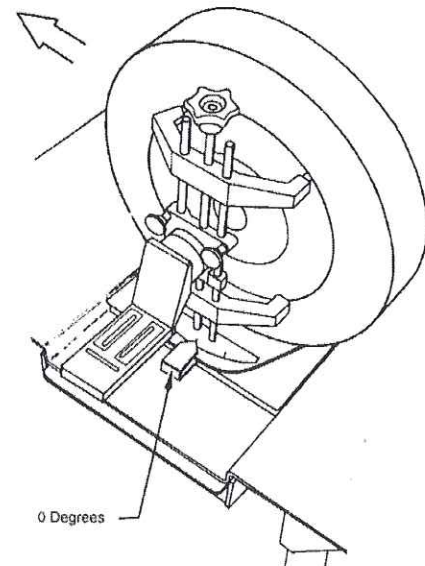

Figure 13

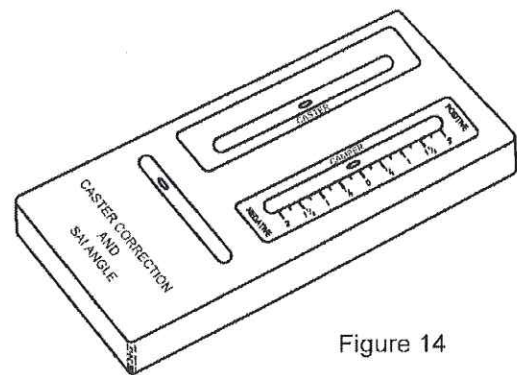

Figure 14

CASTER READING

Proceed with the following steps to read Caster:

- 1) With the Spirit Level Gauge mounted on the left front wheel clamp, turn the left front wheel outward at the front for a 20 degree reading on the radius gauge. (See Fig. 19)
- 2) Turn the Spirit Level Gauge so it is level.
- 3) Adjust the Caster bubble to zero with the adjusting knob on the bottom of the gauge.
- 4) Turn the wheel inward at the front for a 20 degree reading on the radius gauge. This is a total swing of 40 degrees. (See Fig. 20)
- 5) Turn the Spirit Level Gauge so it is level.
- 6) Read Caster at the center of the bubble on the Caster Scale. The spirit level for Caster is located on the left side of the gauge. See the figure to the right. (See Fig. 21)

Caster is zero when the center of the bubble is on zero of the scale.

Caster is positive when the bubble is away from zero, away from the wheel.

Caster is negative when the bubble is away from zero, towards the wheel.

- 7) Repeat the above procedure on the right front wheel.

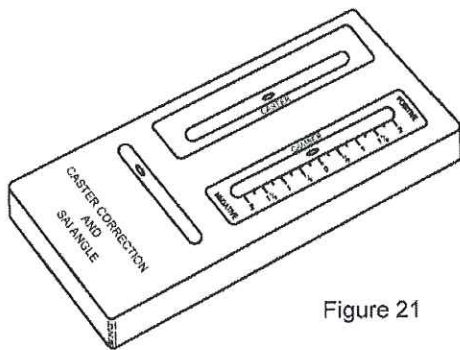
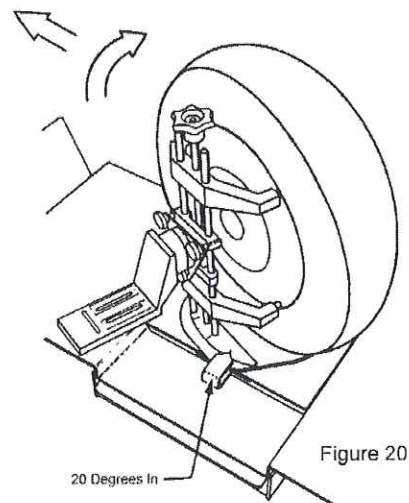
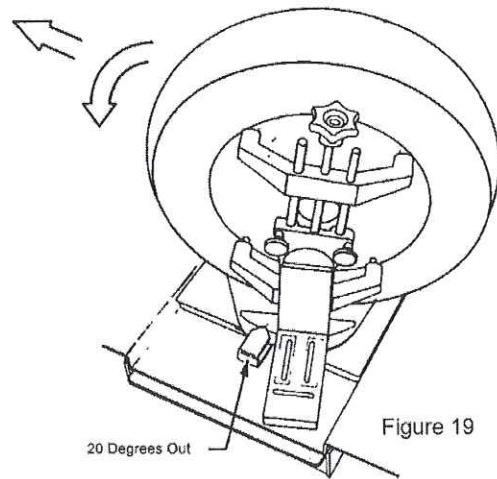

STEERING AXIS INCLINATION (SAI) READING

SAI: The inward tilt of the ball joint or strut at the top

Proceed with the following steps to read SAI:

- 1) With the Spirit Level Gauge mounted on the left front wheel clamp, turn the left front wheel outward at the front for a 20 degree reading on the radius gauge. (See Fig. 24)
- 2) Pivot the Spirit Level Gauge so that the SAI bubble reads zero on scale "L". (See Fig 26)

Note: The bottom scale marked "L" is for the left wheel and the upper scale marked "R" is for the right wheel.

- 3) Turn the wheel inward at the front for a 20 degree reading on the radius gauge. This is a total swing of 40 degrees. (See Fig. 25)
- 4) Read center of SAI bubble for SAI readout. (See Fig. 26)

If the SAI reading is higher than the scale on the gauge, turn the wheel until an 8 degree reading is reached. Re-adjust the gauge for a reading of zero and continue turning the wheel. Add the 8 degrees to the final reading to obtain the actual SAI reading.

- 5) Repeat the above procedure on the right front wheel. Use the scale labeled "R". (See Fig. 26)

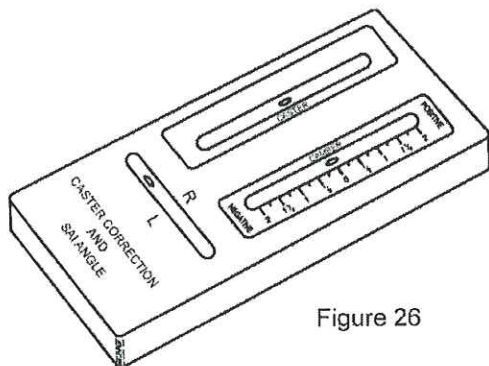
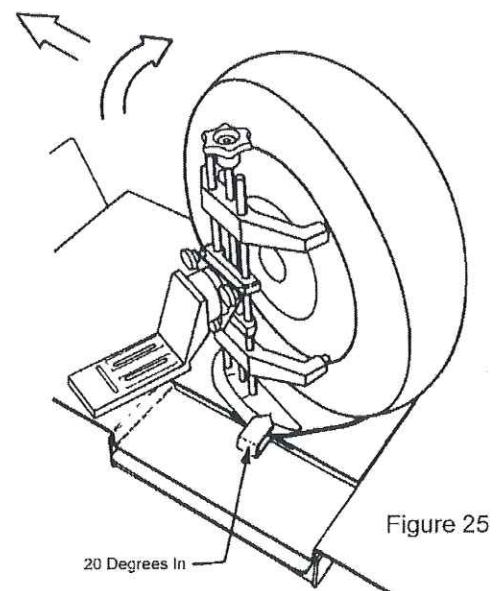
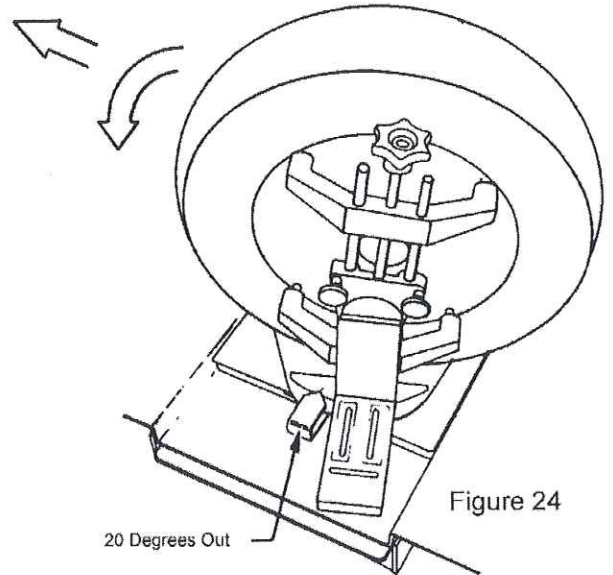

Figure 26

INSTRUMENTATION SET-UP

Center the Steering Wheel:

Center the steering wheel in the straight ahead position and clamp in place with the Steering Wheel Holder. The engine must be running to set the steering wheel position on cars with power steering.

Mount the Left & Right Laser Toe Gauges:

- 1) Determine the manufacturer's preferred total toe specification for the front wheels. Rotate the tapered magnet on each Laser Toe Gauge to **one-half** this specified value. (See Fig. 27)

EXAMPLE: The manufacturer's preferred total toe specification is 0.08 inches Toe In. Rotate both of the tapered magnets to one-half this value which is 0.04 inches.

- 2) Mount the Laser Toe Gauges to the Wheel Clamps. Center the magnet on the Wheel Runout Compensating Adapter. Connect the safety strap to the Wheel Clamp for extra protection against damage. (See Fig. 28)
- 3) Level the Laser Toe Gauges using the spirit level located on the top.
- 4) Flip the power switch to ON and open the protective covers on the laser beams.

Mount the Rear Retro-screens:

- 1) Determine the manufacturer's preferred total toe specification for the rear wheels. Rotate the tapered magnet on each of the Rear Retro-screens to **one-half** this specified value. (See Fig. 27)
- 2) Mount the left and right Rear Retro-screens to the Wheel Clamps. Center the magnet on the Wheel Runout Compensating Adapter. Connect the safety strap to the Wheel Clamp for extra protection against damage.

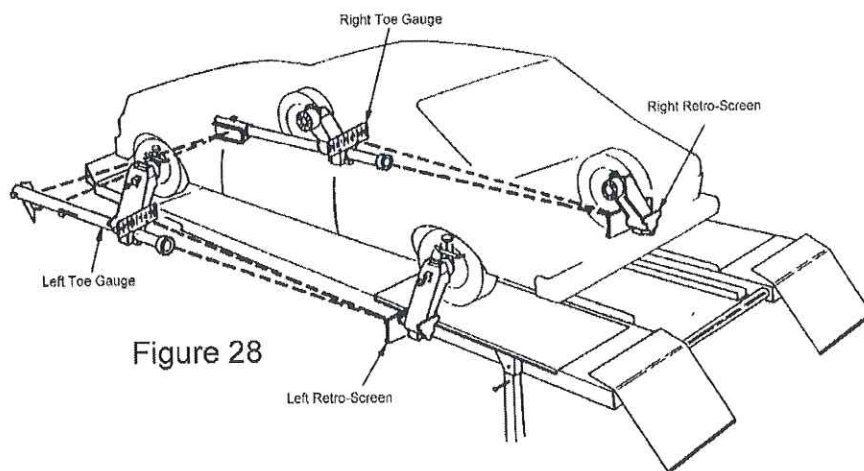
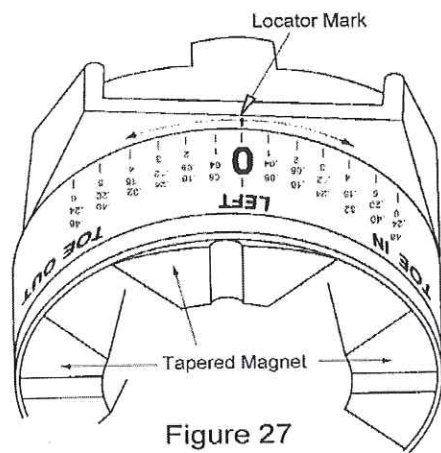

FRONT WHEEL TOE READING

Toe: *The difference in distance between the front and rear of the front wheels*

Toe-in: Distance between front of wheels is less than distance between rear of wheels

Toe-out: Distance between front of wheels is greater than distance between rear of wheels

Adjust Laser Beam Mirror & Target:

The Left Laser Toe Gauge projects a laser beam onto the right mirror (A). This beam is reflected back to the graduated toe scale on the Left Laser Toe Gauge. (See Fig. 29)

Adjust the laser beam vertically to the center of the mirror (A) by using the knob (E) on the Left Laser Toe Gauge. Rotate the laser beam assembly inside the tube of the Left Laser Toe Gauge. Re-tighten knob.

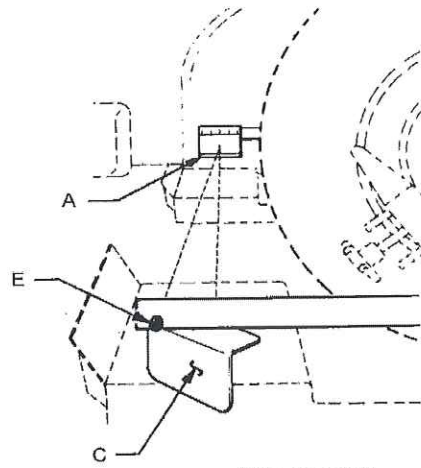

Figure 29

If the laser beam, reflected back from the mirror (A), doesn't strike the graduated toe scale, loosen both knobs (R) on the Right Laser Toe Gauge (See Fig. 30). Rotate the mirror housing (A) until the laser beam image strikes the graduated toe scale. Re-tighten both knobs.

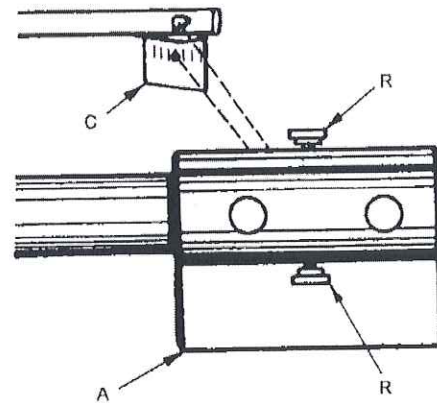

Figure 30

Reading Front Wheel Toe:

Read Front Wheel Toe on the graduated toe scale on the Left Laser Toe Gauge. (See Fig. 31)

Toe is within spec if the laser beam image is in the center of the scale at zero.

IN		TOTAL TOE		OUT								
.48	.40	.32	.24	.16	.08	0	.08	.16	.24	.32	.40	.48
DEGREES												
.24	.20	.16	.12	.08	.04	0	.04	.08	.12	.16	.20	.24
INCHES												
6	5	4	3	2	1	0	1	2	3	4	5	6
MM												

Figure 31

One-half of the manufacturer's total toe specification is already dialed in with each of the magnets, so a reading of zero on these scales means the toe is correctly adjusted to the manufacturer's specification.

TOE READING ILLUSTRATIONS

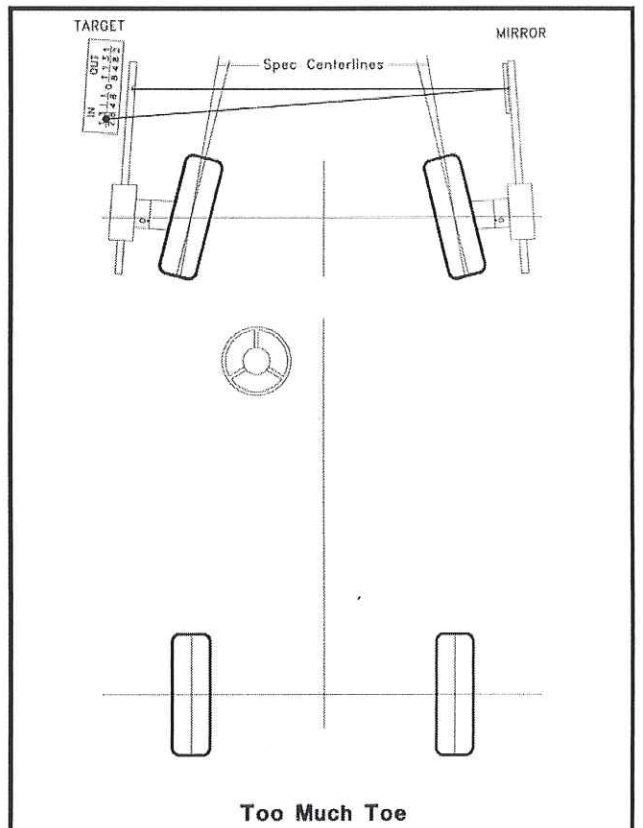
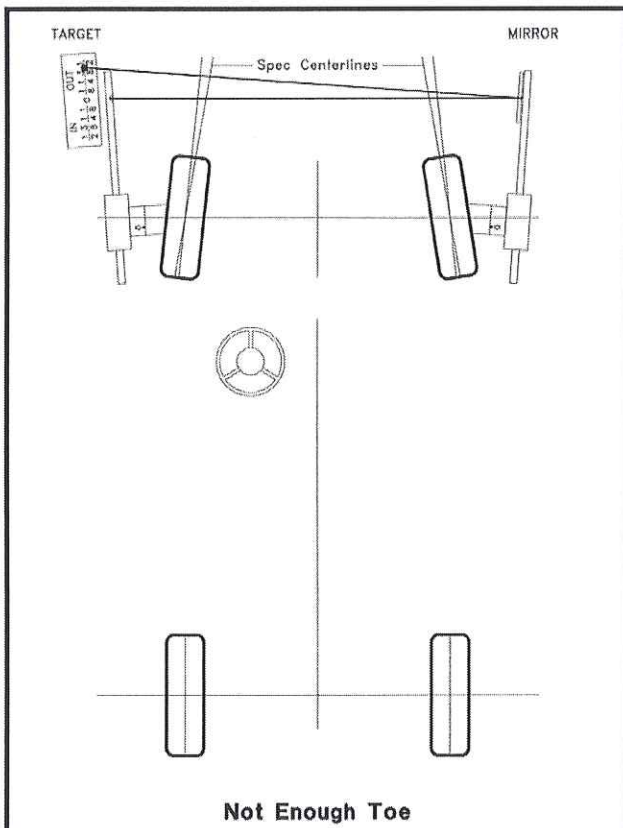
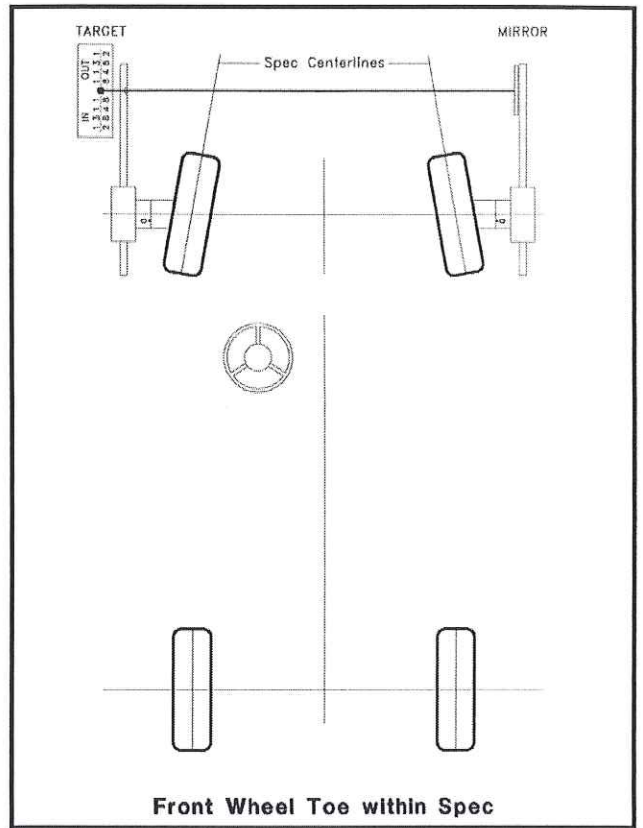
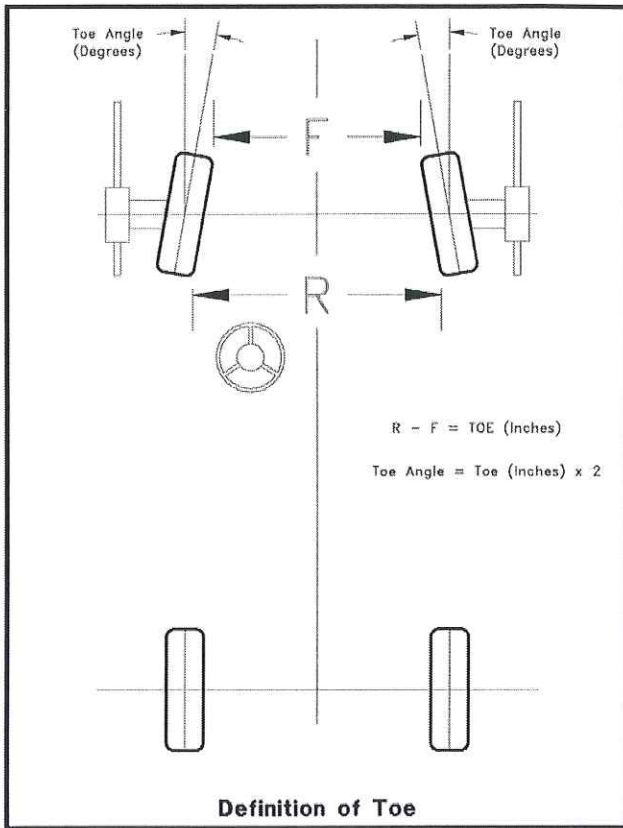

FRONT WHEEL ALIGNMENT VEHICLE CENTERLINE

- 1) Project the laser beams from the Left and Right Toe Gauges onto the Rear Retro-screens. If the beam does not strike the rear mirror, check the level of the Laser Toe Gauge. (See Fig. 32)
- 2) Note the readings on the scales of the rear screens. Add both readings and divide by two.
- 3) Adjust both tie rods or tie rod adjusting sleeves equally so that the rear screens register the desired reading determined in Step 2.

EXAMPLE:

One rear wheel screen registers 5 (See Fig. 33) and the other one registers 7 (See Fig. 34), the total is 12.

Divide by 2 and adjust both tie rods equally until the laser beam falls on 6 on each retro screen.

- 4) Re-check front wheel toe to be sure it remains on zero. If not, re-adjust front wheel toe to zero. Re-check the rear retro-screens for equal readings.

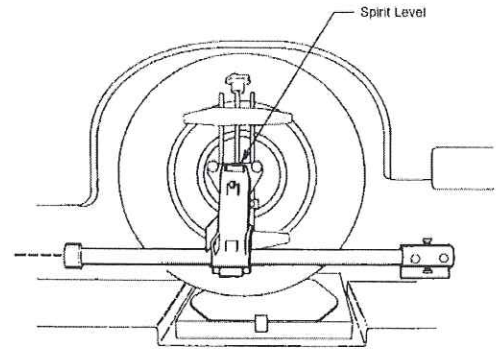

Figure 32

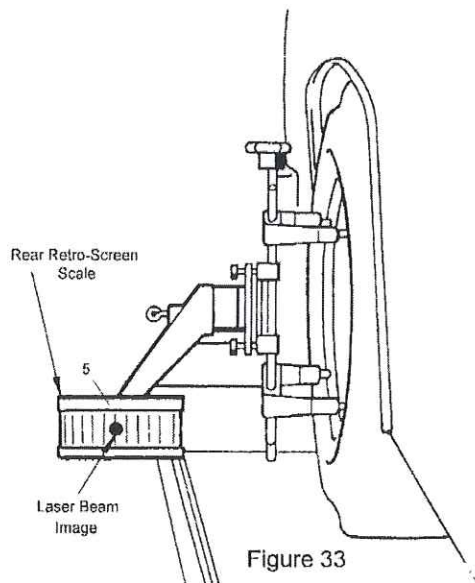

Figure 33

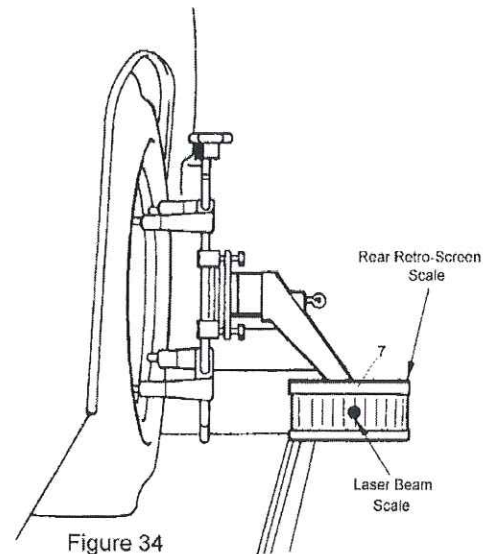

Figure 34

This is a "Two Wheel Alignment"

THRUST ANGLE ALIGNMENT

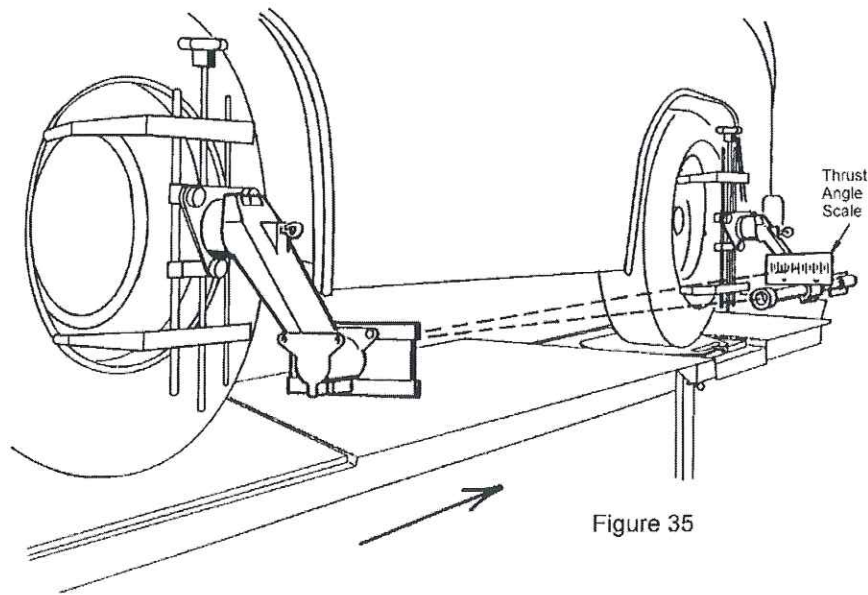

Figure 35

- 1) Check that both Laser Toe Gauges are level. The laser beams should be visible on the rear Retro-screen mirrors (See Fig. 35).
- 2) Rotate the rear Retro-screen assemblies out of level, if necessary, so that the laser beams will be reflected back to the front Toe Gauges and be visible on the Thrust Angle Scales.
- 3) Note the readings on the Thrust Angle Scales. Add both readings and divide by two.
- 4) Adjust both tie rods or tie rod adjusting sleeves equally so that the Thrust Angle Scales register the desired reading determined in Step 3.

EXAMPLE:

One Thrust Angle Scale registers 4 (See Fig. 36) and the other one registers 6 (See Fig. 37), the total is 10.

Divide by 2 and adjust both tie rods equally until the laser beam falls on 5 on each Thrust Angle Scale. (See Fig. 39 and Fig. 40)

Right Rear Thrust Angle Scale

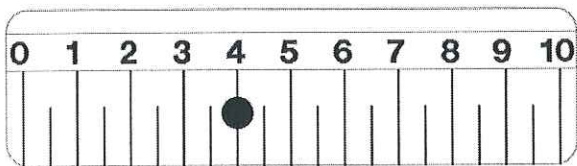

Figure 36

Left Rear Thrust Angle Scale

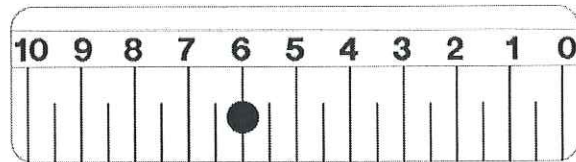

Figure 37

This is a Thrust Angle Alignment where the front wheel position is corrected for rear wheel misalignment.

Total Vehicle Four-Wheel Alignment

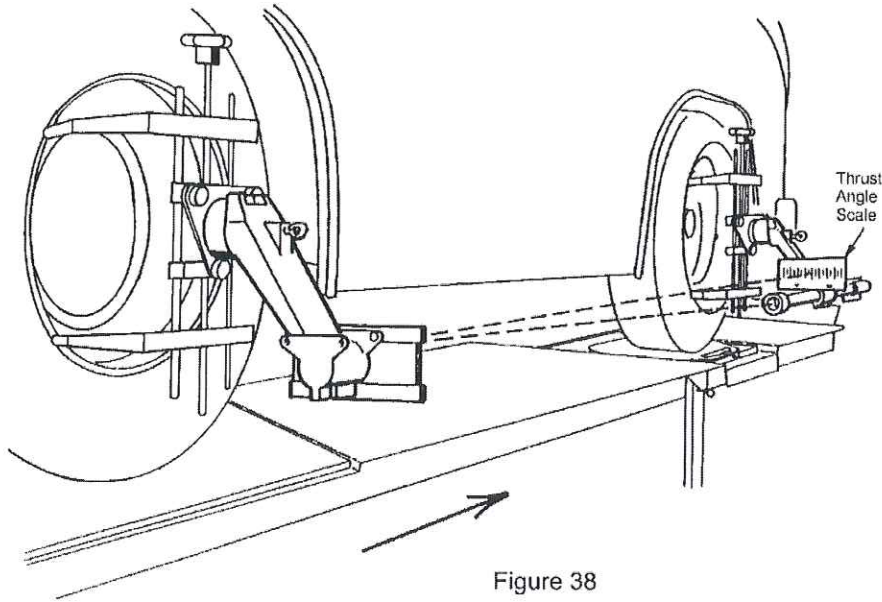

Figure 38

- 1) Check that both Laser Toe Gauges are level. The laser beams should be visible on the rear Retro-screen mirrors.(See Fig. 38)
- 2) Rotate the rear Retro-screen assemblies out of level if necessary, so that the laser beams will be reflected back to the front Toe Gauges and be visible on the Thrust Angle Scales.
- 3) Note the reading on each of the Thrust Angle Scales. Adjust the toe of each rear wheel until the laser beam image on the corresponding Thrust Angle Scale is in the middle at the number 5. (See Fig. 39 and Fig. 40)

Right Rear Thrust Angle Scale

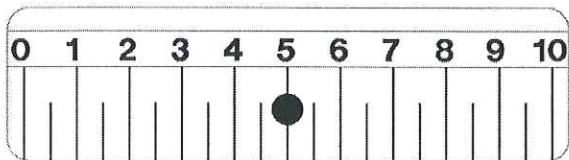

Figure 39

Left Rear Thrust Angle Scale

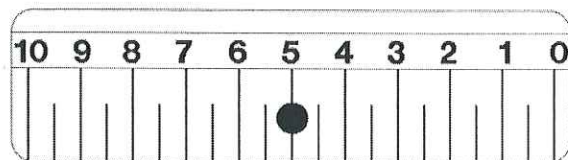

Figure 40

This completes a four-wheel alignment.

CALIBRATION PROCEDURE

Mount and level the Calibration Bar on Calibration Stands or the rear of the Storage Cart

Calibration of Front Wheel Toe Laser Beam (See Figure 42)

- 1) Rotate the tapered magnets on the Left and Right Toe Gauges to zero.
- 2) Mount the Left and Right Toe Gauges on the ends of the Calibration Bar. Be sure the centers of the magnets fit over the raised machined surfaces at the ends of the Calibration bar. (See Fig. 41)

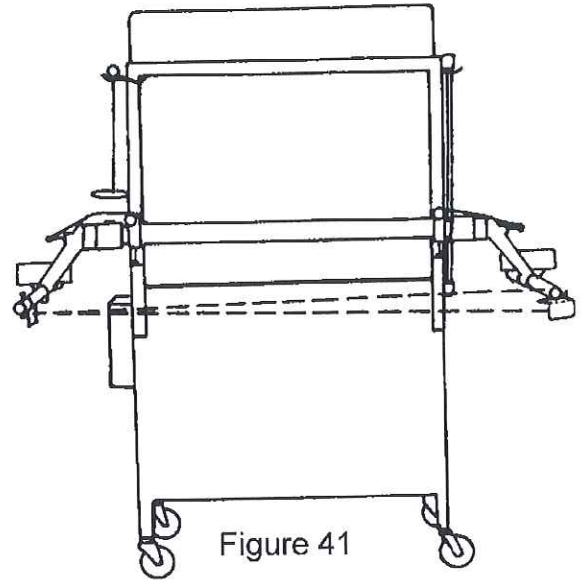

- 3) Level both Toe Gauges and check the laser beam on the mirror screen (A). If the laser beam image is not located midway up on the mirror screen (A), loosen the knob (E) on the Left Toe Gauge and slide it up or down. This moves the laser beam image vertically until it is on the mirror.
- 4) The center of the laser beam image should be on zero on the screen (A). If not, alternately adjust Allen set screws of the laser diode bulb retainer on the Left Toe Gauge until the center of the beam image reads zero on the Right Toe Gauge screen (A).
- 5) Adjust the mirror (A) up or down as required so the reflected laser beam image is on the front toe scale. Loosen knobs (R) to make any required adjustments.
- 6) Adjust Allen set screws (F) until the center of the laser beam image reads zero on the front toe scale (C).

CALIBRATION PROCEDURE

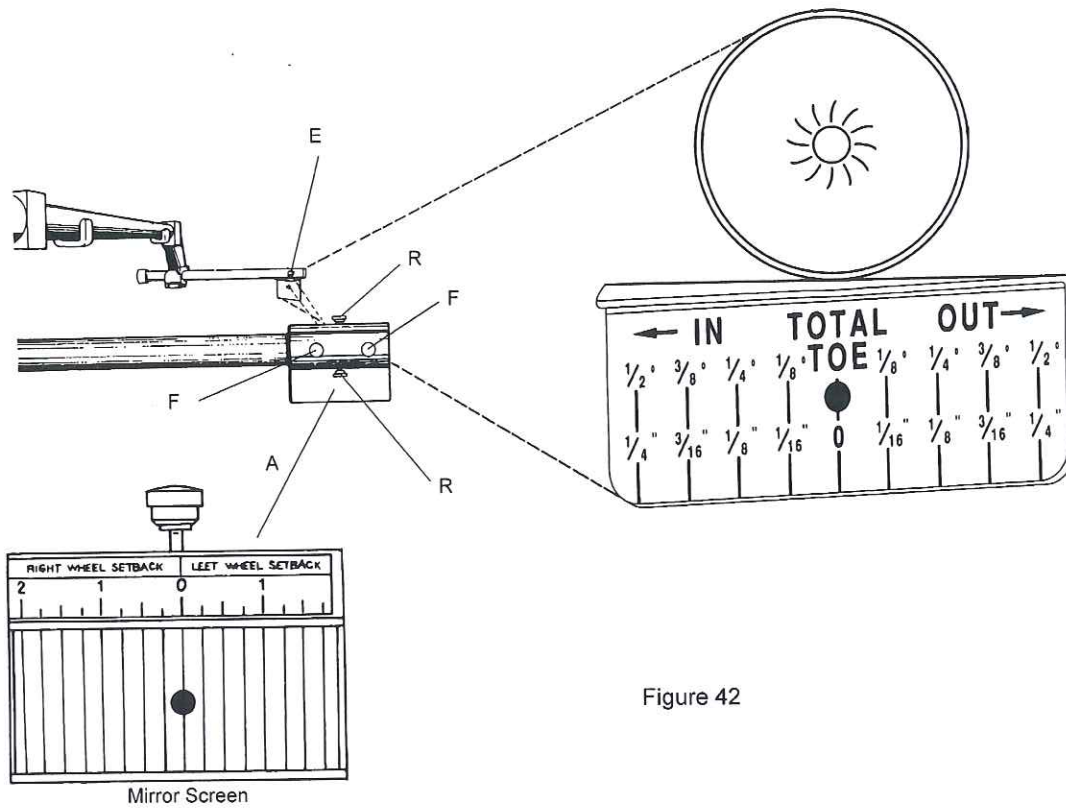

Figure 42

The Gauges are now parallel - "Toe reads zero"

Calibration of Right & Left Toe Gauge Laser Beams

- 1) Rotate all tapered magnets on the Toe Gauges and Rear Retro-screens to zero
- 2) Mount the Left Toe Gauge and Left Retro-screen to the machined surfaces on the side of the Calibration Bar. (See Fig. 43)

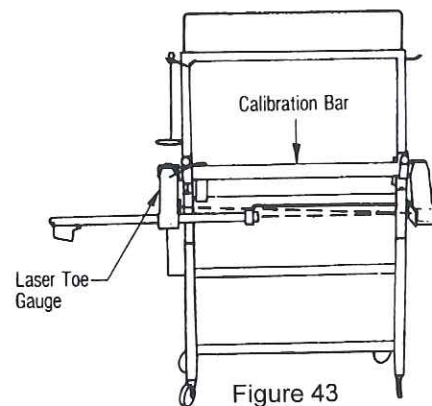

Figure 43

CALIBRATION PROCEDURE

Calibration of Right & Left Toe Gauge Laser Beams (continued)

- 3) Level the Toe Gauge and project the laser beam image on the rear Retro-screen. (See Figure 44) The center of the beam image must be on 6 and midway up the mirror.

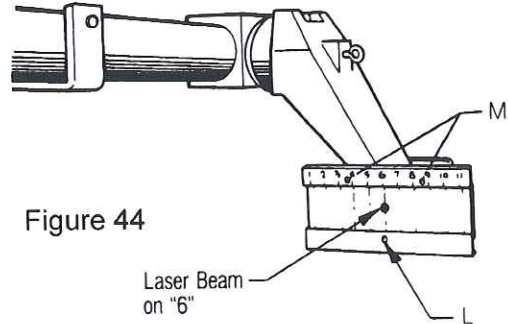

Figure 44

- 4) Check the location of the reflected laser beam image on the Thrust Angle Scale on the Laser Toe gauge.

With the Rear-retro Screen level, the center of the image should be mid-way up and on 5 on the Thrust Angle Scale.

If not, adjust the two screws (M) (See Fig. 44) until the image is on 5 and adjust screw (L) until the image is mid-way up on the Thrust Angle Scale.

- 5) Remove the Left Toe Gauge and Left Retro-screen. Mount the Right Toe Gauge and Right Retro-screen and repeat steps 1 through 4.

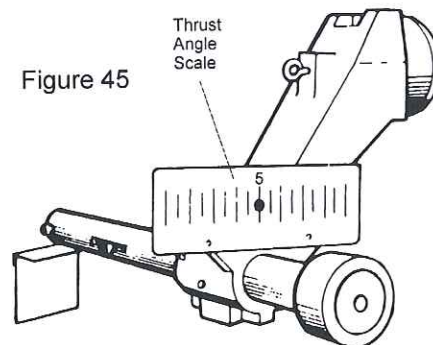

Figure 45

The Retro-screen is now at a perfect 90 degree angle to the front Toe Gauge and the laser beam image indicates zero toe on the Thrust Angle Screen.
